

# Integrated Power Management IC For IMVP8™ Platforms

## ISL95908

The [ISL95908](#) is a Power Management Integrated Circuit (PMIC) for ultrabook, notebook and tablet computers powered by 2-cell Li-ion batteries. It integrates control, MOSFET drivers, power MOSFETs, fault protection and fault monitoring functions for 8 highly efficient synchronous buck regulators and VTT LDO. It is offered in a thermally efficient 5.5mmx5.5mm, 121-bump, 0.5mm pitch WLCSP package.

The PMIC regulators convert system voltage from the battery or adapter into all platform voltages needed for a typical computer system including 5V and 3.3V system regulators, 1.8V/2.5V, 1V, 0.975V, 0.9V for controller-hub, peripheral and core voltages as well as programmable VDDQ and VTT regulators for DDR3/3U/3L, LPDDR3 and DDR4 voltages. The switching regulators operate at 1MHz and are based on Intersil's proprietary R4™ Technology, which provides high light-load efficiency, fast transient response, seamless DCM/CCM transitions and requires no external compensation.

The PMIC provides overcurrent, overvoltage and over-temperature fault protections and undervoltage and over-temperature warnings. A temperature alert signal indicates the PMIC is operating at an elevated temperature and ALERT indicates if any other fault or warning has occurred. The PMIC also offers significant I<sup>2</sup>C capability and can be configured to provide 8 GPIO pins for additional system functionality and each regulator has an independent power-good indicator.

## Features

- Highly integrated power management IC
- Efficient 1MHz integrated FET switching regulators
- Internal compensation, no external compensation
- Computer system platform voltage regulators 5V, 3.3V, 1.8V/2.5V, 1V, 0.975V, 0.9V
- Programmable VR3 and VTT regulators for memory (DDR3/L/U, LPDDR3 and DDR4)
- Extensive fault protection
  - Overcurrent protection
  - Over-temperature protection
  - Overvoltage and undervoltage protection
  - Temperature alert signal
- Independent power-good indicator for each regulator
- Independent enable signals for each regulator for maximum sequencing flexibility
- Low power consumption mode for connected standby
- I<sup>2</sup>C bus allows system fault monitoring, enable control and configurable GPIO programming
- Output voltage offset programming through I<sup>2</sup>C
- Configuration pin provides additional system programming options

## Applications

- Ultrabook, notebook and tablet computers

## Related Literature

- UG027, "ISL95908EVAL1Z Evaluation Board User Guide"

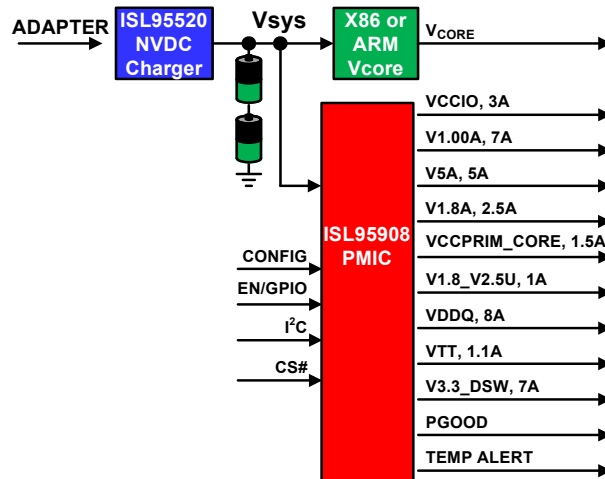

FIGURE 1. COMPUTER SYSTEM POWER MANAGEMENT SOLUTION

For additional products, see [www.intersil.com/en/products.html](http://www.intersil.com/en/products.html)

---

Intersil products are manufactured, assembled and tested utilizing ISO9001 quality systems as noted in the quality certifications found at [www.intersil.com/en/support/qualandreliability.html](http://www.intersil.com/en/support/qualandreliability.html)

---

*Intersil products are sold by description only. Intersil Corporation reserves the right to make changes in circuit design, software and/or specifications at any time without notice. Accordingly, the reader is cautioned to verify that data sheets are current before placing orders. Information furnished by Intersil is believed to be accurate and reliable. However, no responsibility is assumed by Intersil or its subsidiaries for its use; nor for any infringements of patents or other rights of third parties which may result from its use. No license is granted by implication or otherwise under any patent or patent rights of Intersil or its subsidiaries.*

---

For information regarding Intersil Corporation and its products, see [www.intersil.com](http://www.intersil.com)